ITS of SMART

(Storm Management And Road Tunnel)

August 2006

by

Ir Mohd Saleh Santhiman, Director of SMART Highway, LLM
Looi Hong Weei, HOD-M&E, MGJV

Content

- **Overview**
- **3 Modes of Operation**
- **Stormwater Components**
 - Flood Detection System
 - Flood Gate / Road Gate
- **Motorway Components**
 - Ventilation System
 - Lighting System
 - Heat Detection System
 - Fire and Emergency System
 - Radio Communication and Cellular System
 - CCTV
- **Event 1 : Tunnel Closure from Mode 2 to Mode 3**
- **Event 2 : Traffic Accident**
- **Event 3 : Fire Accident**

Overview

- The dual-purpose SMART tunnel is able to solve 2 main problems in Kuala Lumpur

a) Resolves the flood problem in the city and other flood prone areas, and

b) Eases traffic congestion on the main southern gateway to the city at Sg. Besi airfield

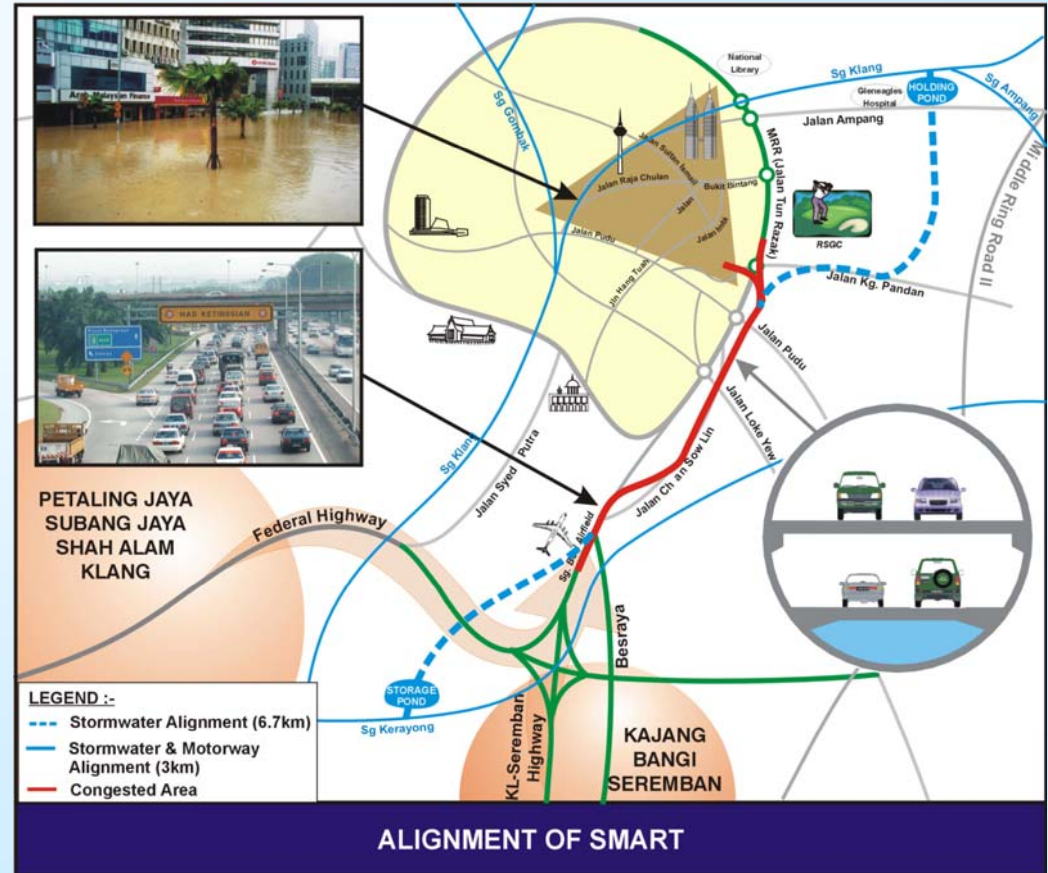

Overview

- 3 km in the central portion of 9.7 km tunnel is for dual purposes
- About 6 km motorway tunnel

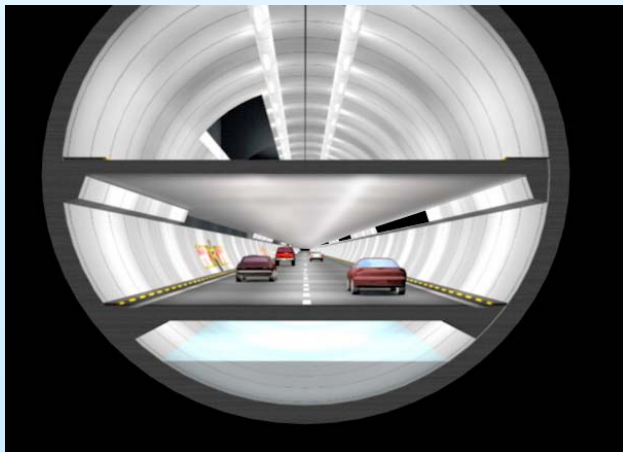
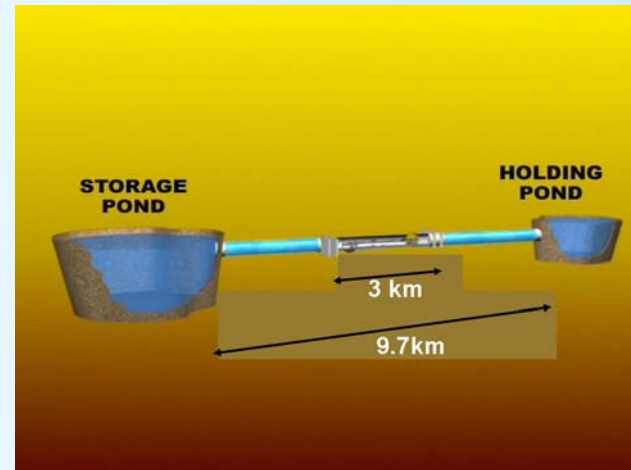

- Unidirectional traffic flow - reduce accident risk
- 2 traffic lanes and 1 emergency lane – expedite emergency response
- Vehicle restriction - light vehicle only, < 2.0m height

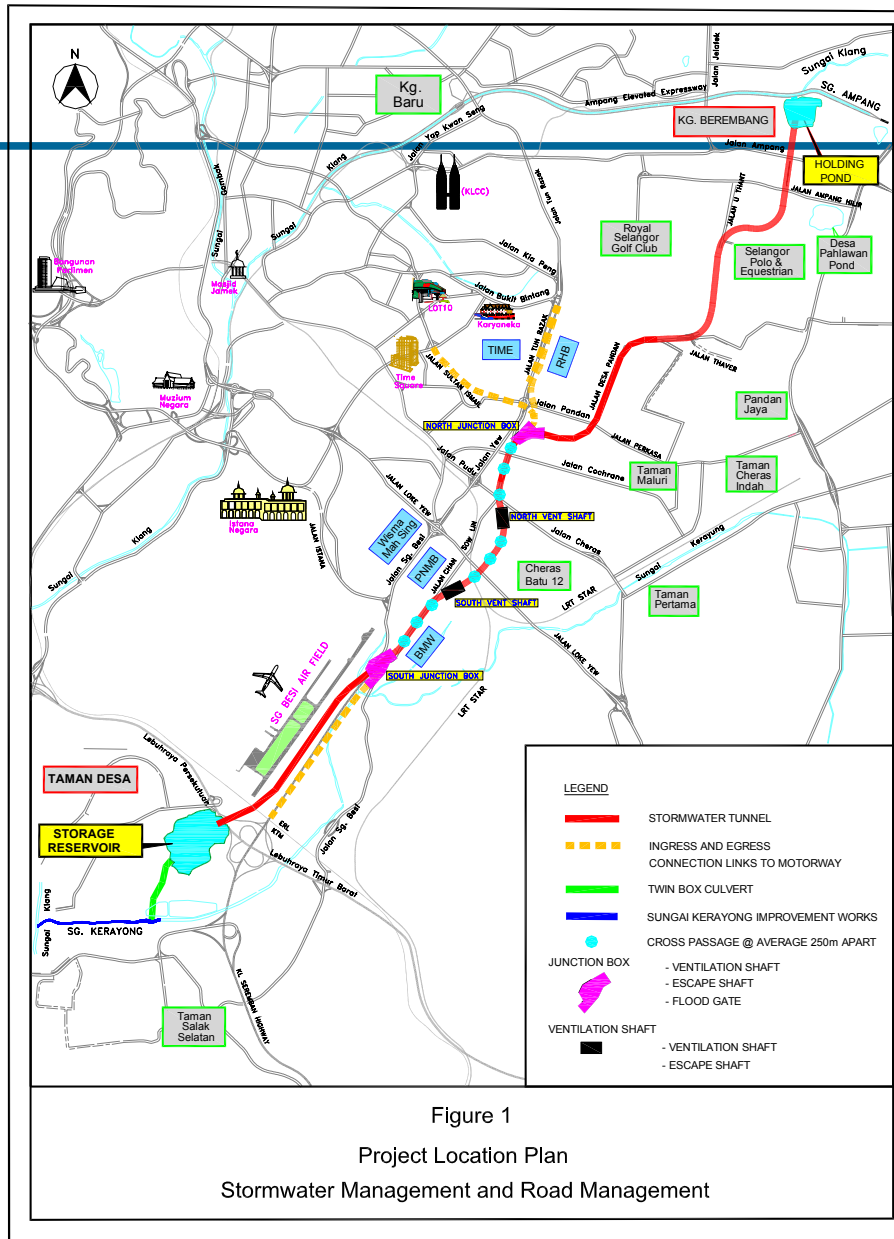
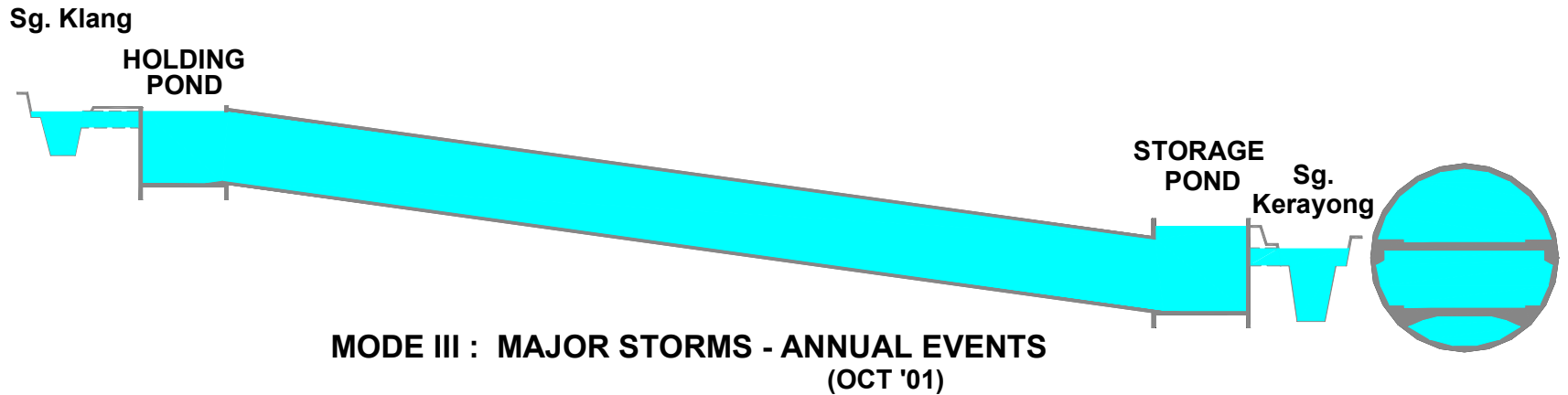

Figure 1
 Project Location Plan
 Stormwater Management and Road Management

3 Modes of Operation

DUAL-PURPOSE USAGE OF SMART



Stormwater Components

Flood Detection System : Catchment Monitoring & Warning System

- Rainfall Gauging Stations
- Water Level Gauging Stations
- River Flow Monitoring
- Warning Stations
- Remote Terminal Unit
- Radio Telemetry
- Repeater Stations
- Radar System (future)

Flood Detection System : Weather Stations layout

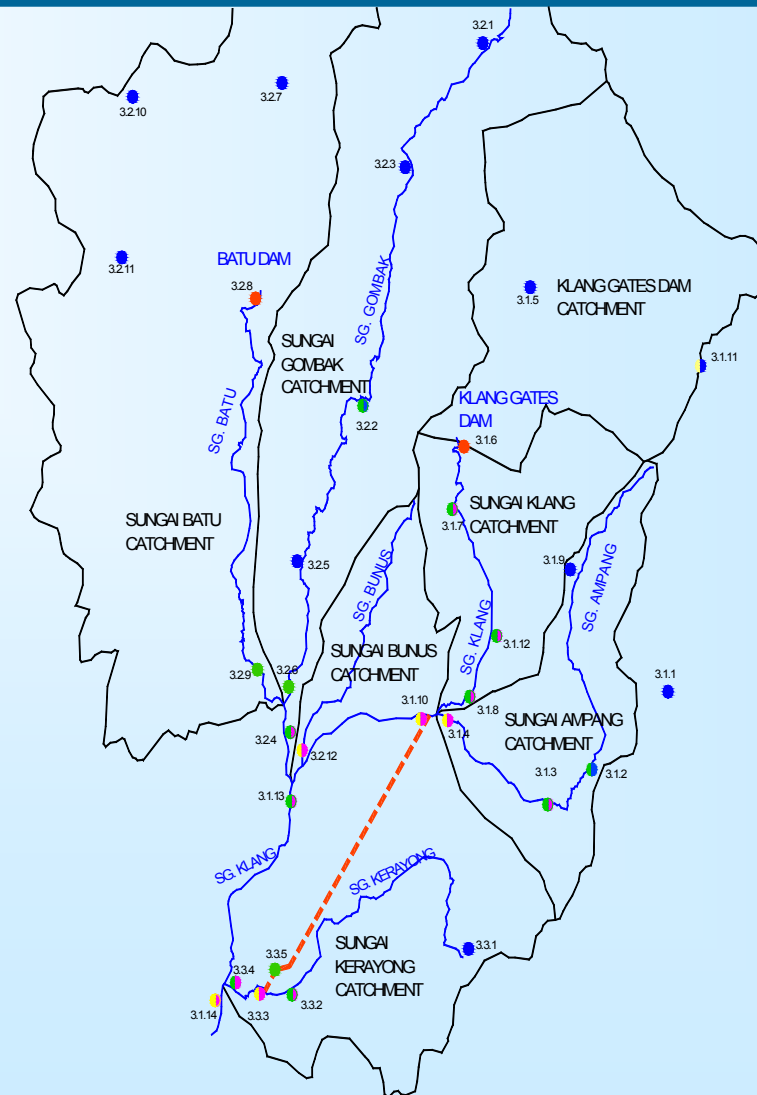
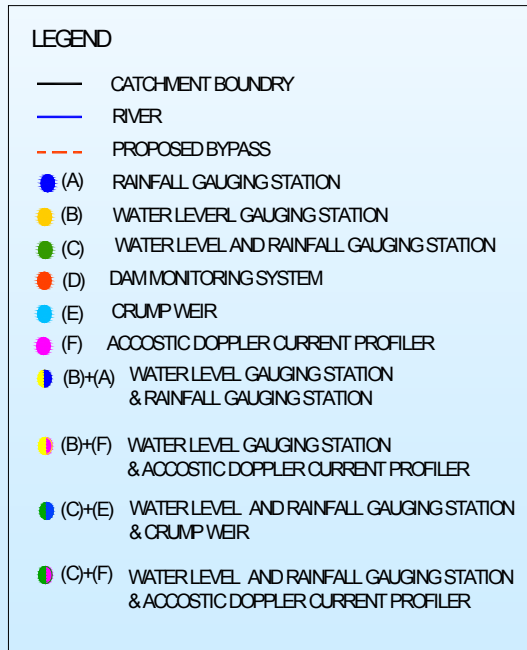

Flood Gates : North Junction Box / South Junction Box

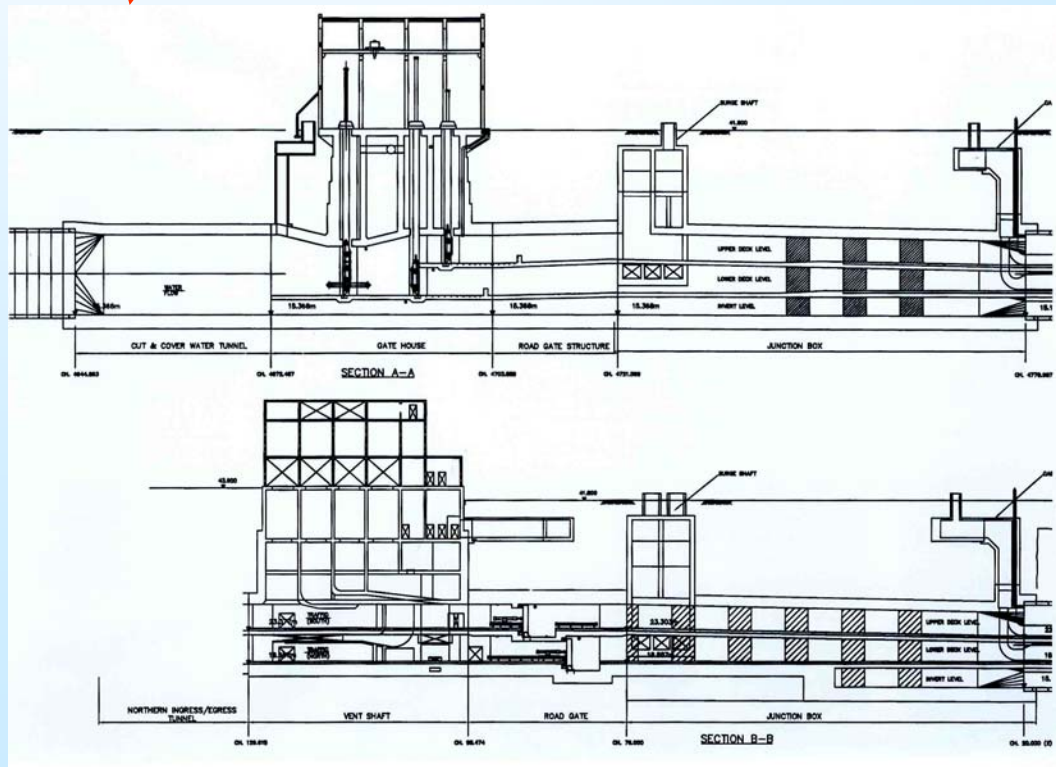
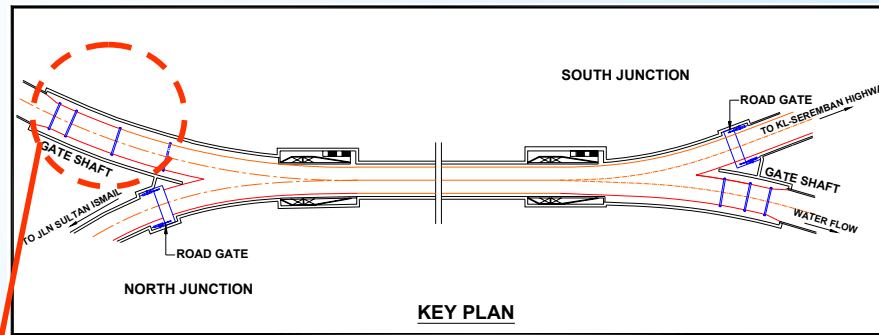

Road Gates : North Junction Box / South Junction Box

- Prevention of vehicles entry during storm events
- Prevention of flood discharge entering to the ingress/egress connection

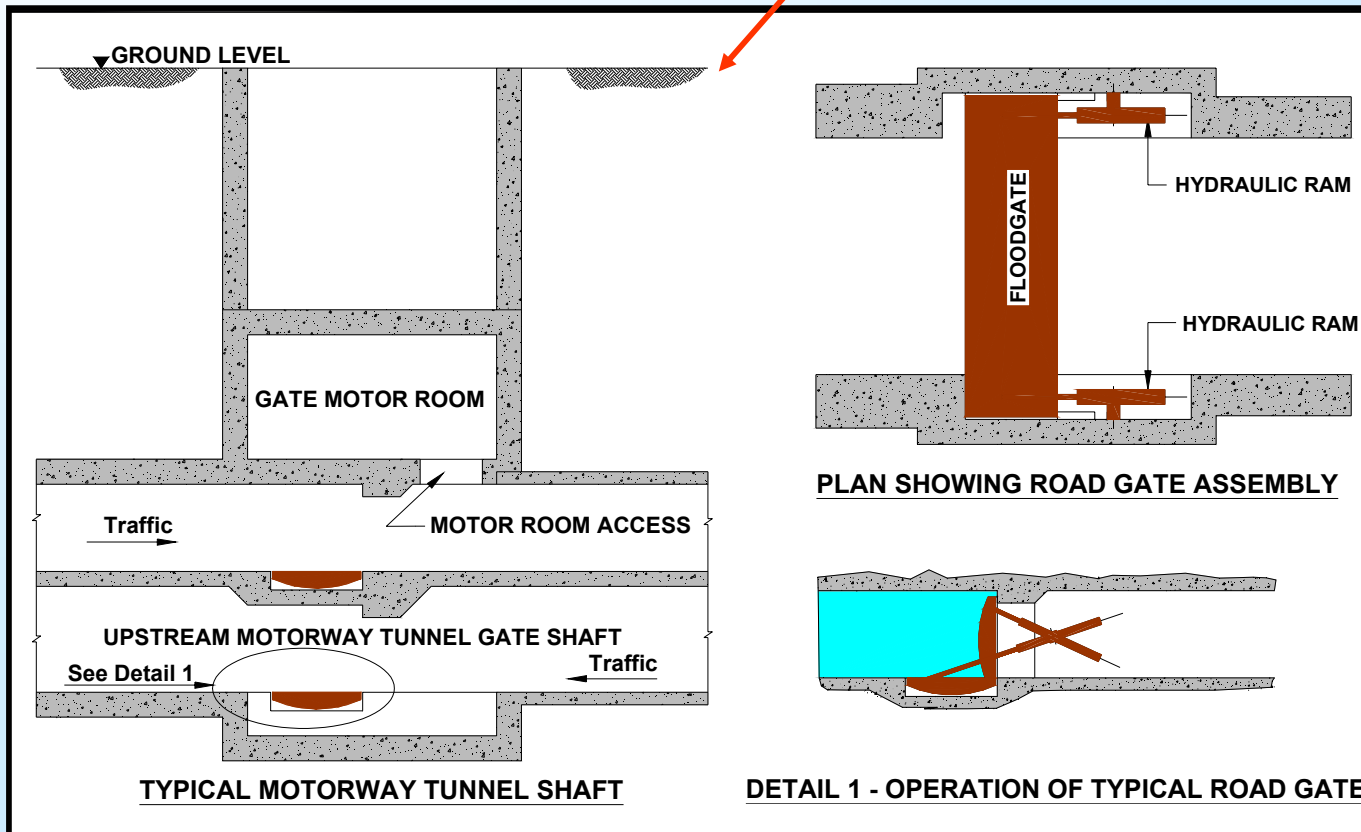
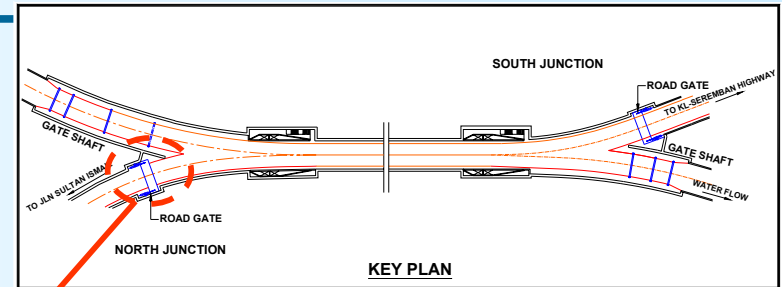

Motorway Components

Typical Tunnel Section

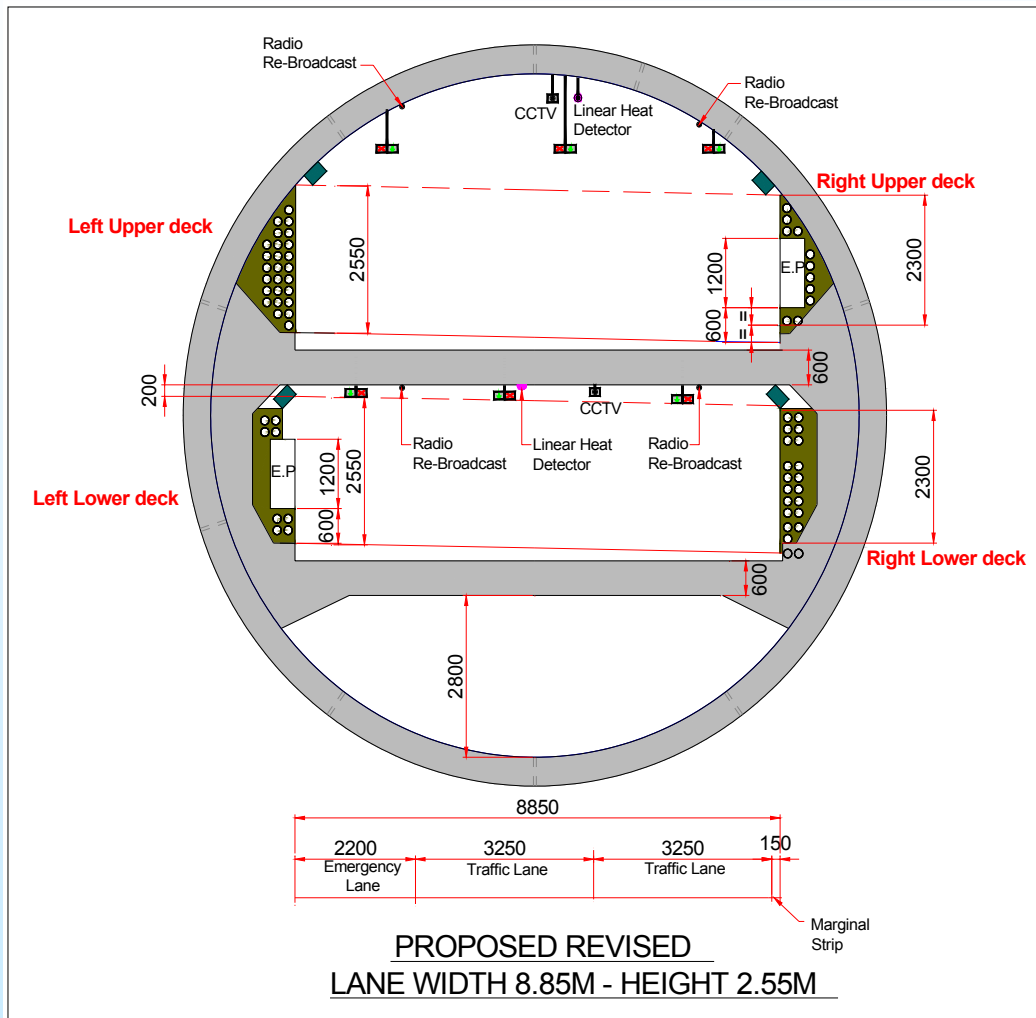

- Heat Detection
- Tunnel Lighting
- Hydrant and etc.
- Leaky Feeder Cable for Radio and Cellular
- CCTV
- Lane Traffic Signal
- Gas Analyzer

Tunnel Ventilation (Upper Deck)

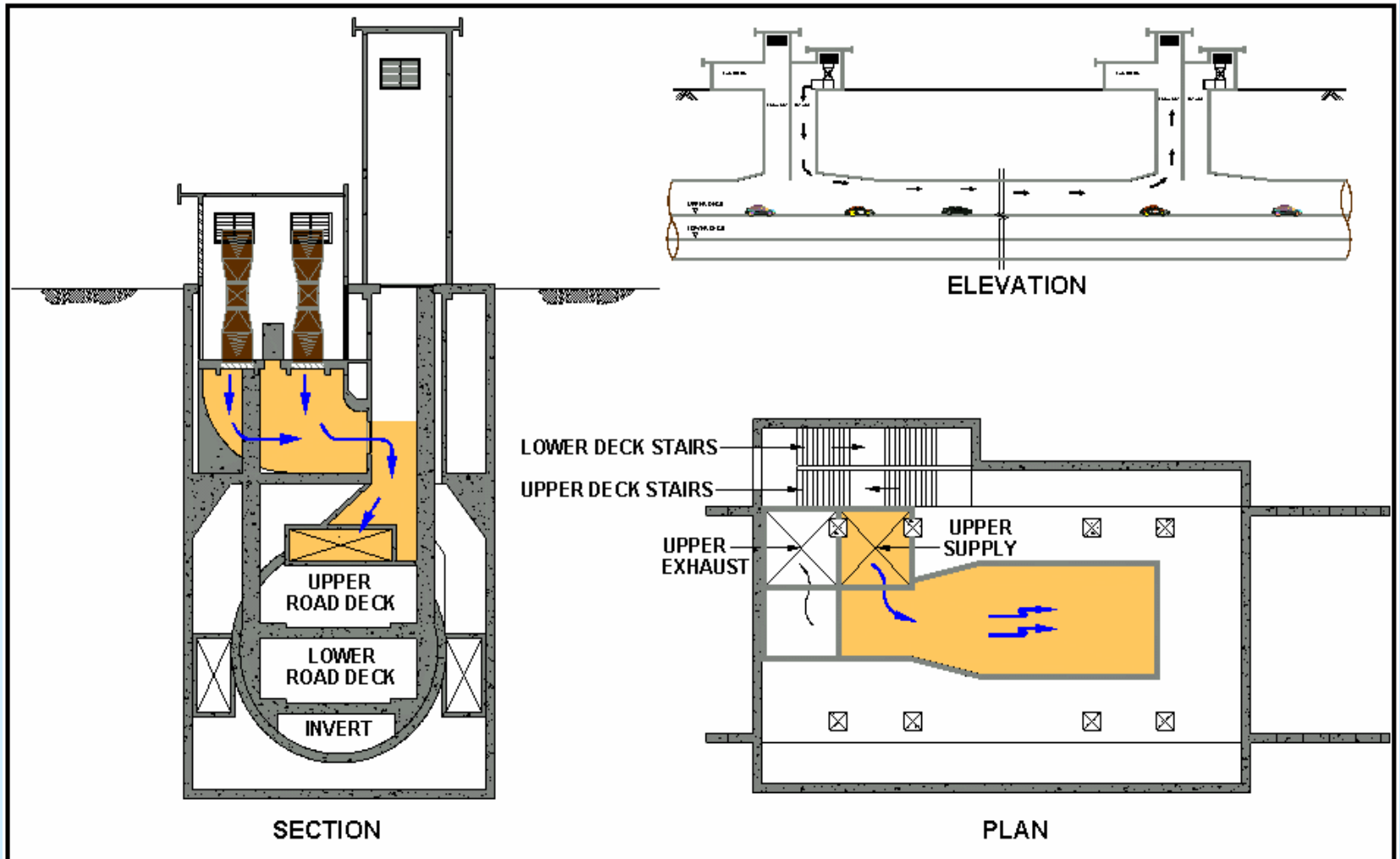

Tunnel Ventilation (Lower Deck)

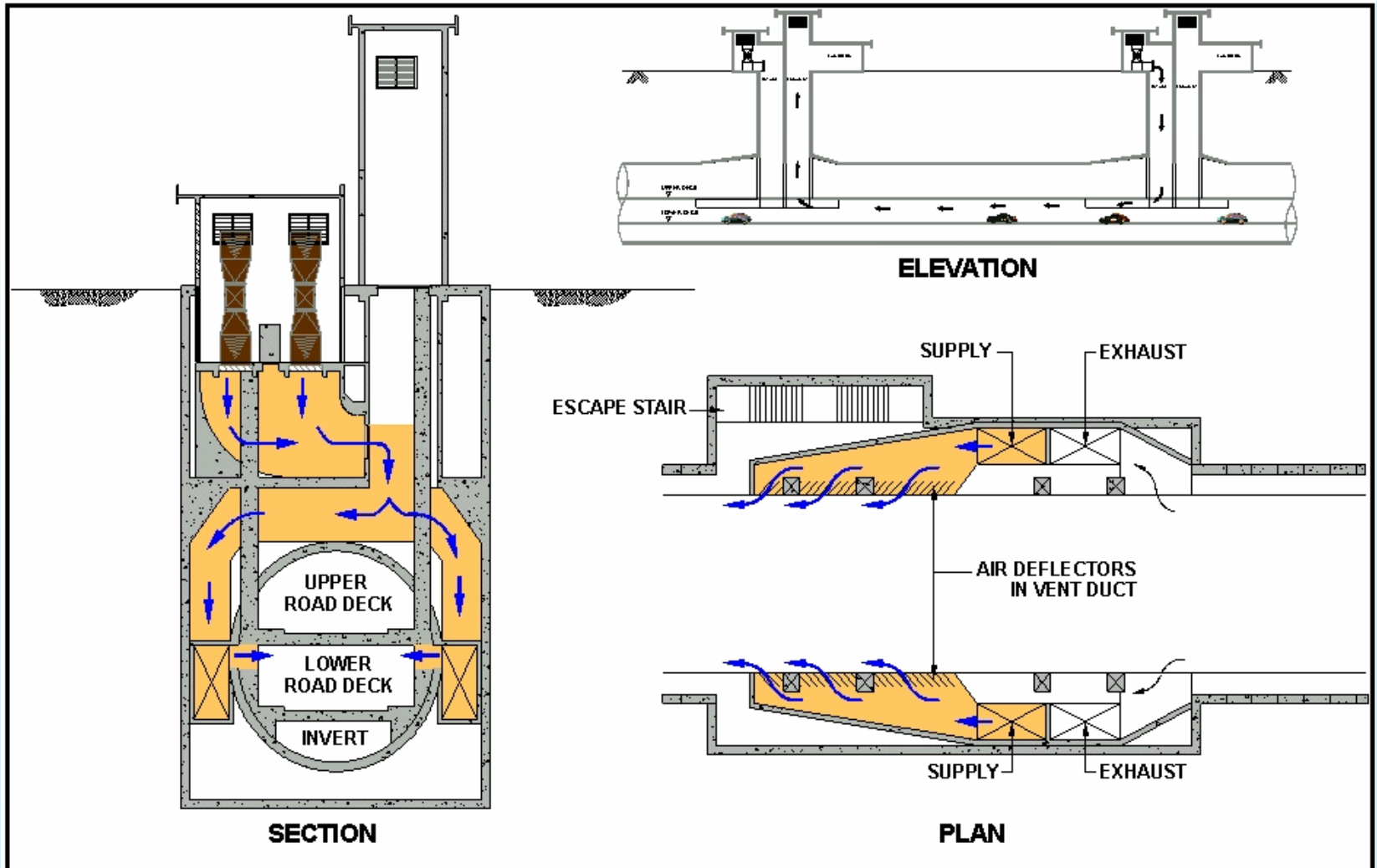

Tunnel Lighting

- To provide continuity in visual performance for motorists entering and travelling through road tunnel.
- IP 68 enclosure and subjected to 2.5 Bar water pressure and bracket design shall withstand 5.5 m/s flow.

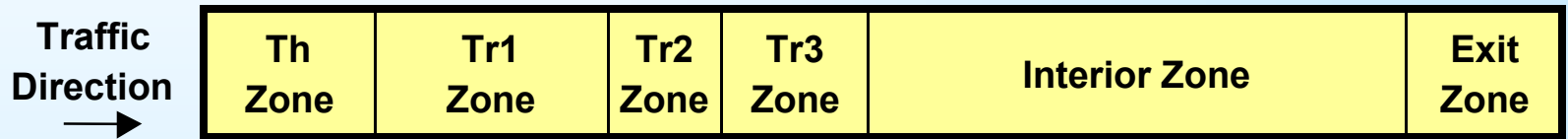

Th - Threshold Zone
Tr1 - Transition Zone 1
Tr2 - Transition Zone 2
Tr3 - Transition Zone 3

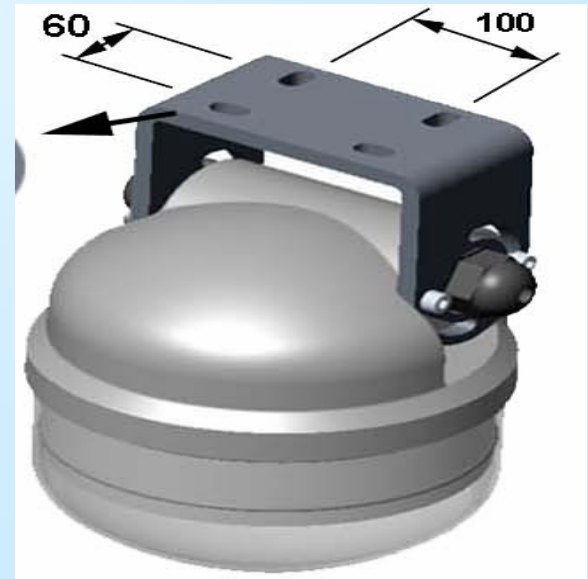

Tunnel Heat Detection System

- The system will respond to the rate of temperature rise, about 10 seconds.
- Programmable fire zones
- Triggering CCTV system and Fire Alarm System during the case of tunnel fire.

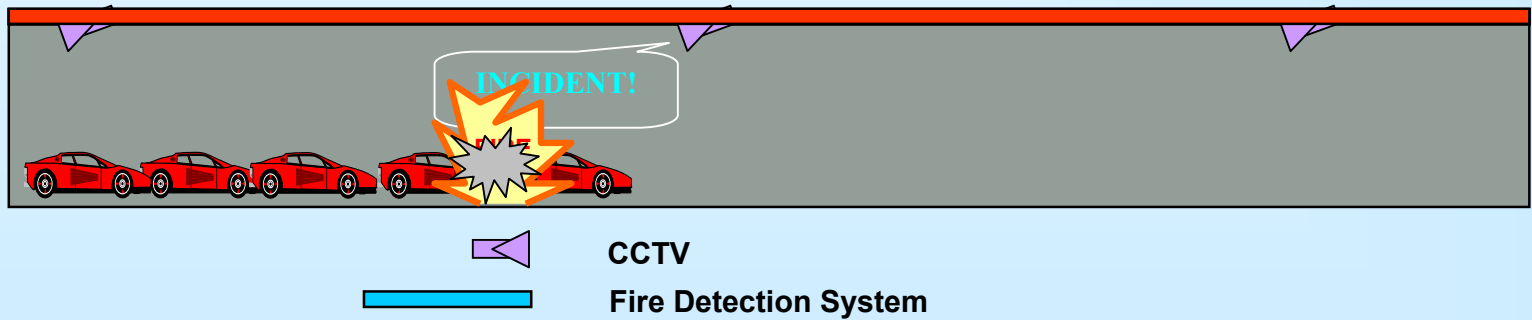

Tunnel Fire Protection : Emergency Points And Equipment

- Hose Reel, Fire Extinguishers, Breakglass and Emergency Telephone are located at each cross passages, ventilation shafts and escape shafts.
- Hydrants & Fire Extinguisher are installed along the tunnel

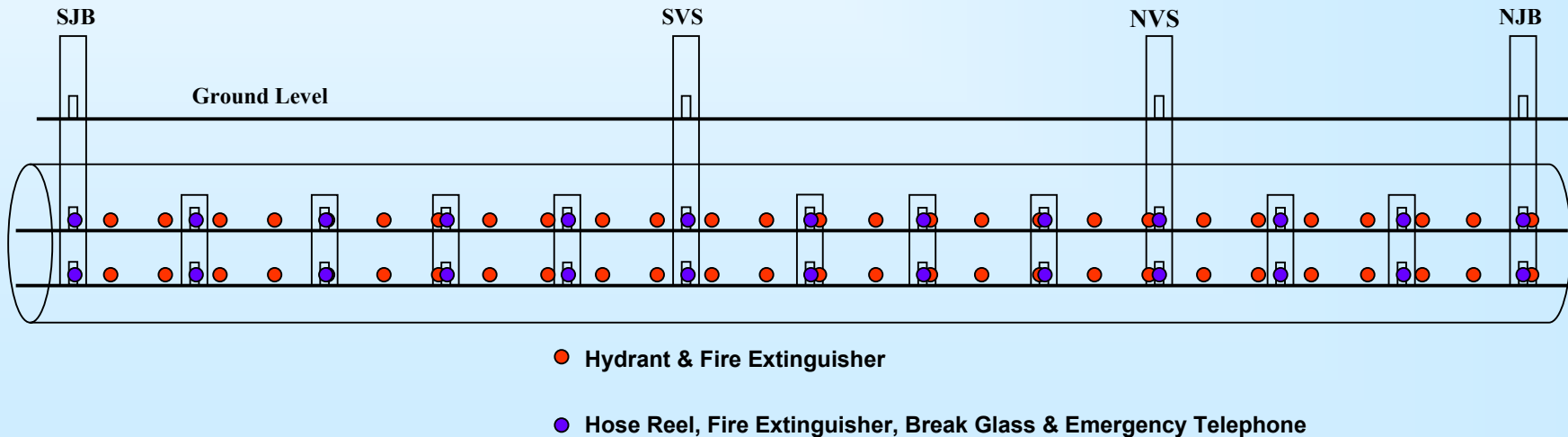

Tunnel Radio Communication and Cellular System

- Re-broadcast FM radios, cellular (telco), fire department, police and ambulance signal into the tunnel.
- Audio break-in facility to broadcast emergency messages from the control center into the tunnel through FM frequencies.
- IP 68 antenna installed to enable the use of mobile phones.
- Public Address and emergency phone are provided in the cross passages and escape shafts.

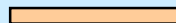
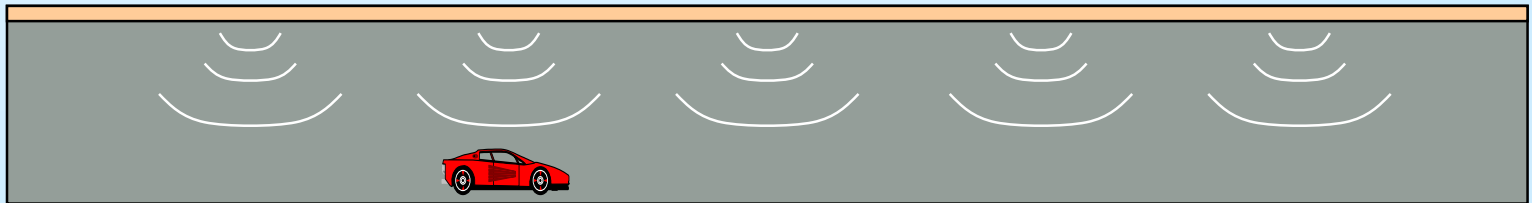

LEAKY FEEDER

CCTV

- Tunnel Surveillance
 - PTZ CCTV at selected locations
 - Fixed CCTV along the tunnel
 - Linked to Fire Detection System
 - Linked to Control Center via Fiber Optic Cable
- Automatic Incident Detection
 - Measurement of traffic flow speed, occupancy count
 - Detection of speed drop, stop vehicles, inverse direction and smoke

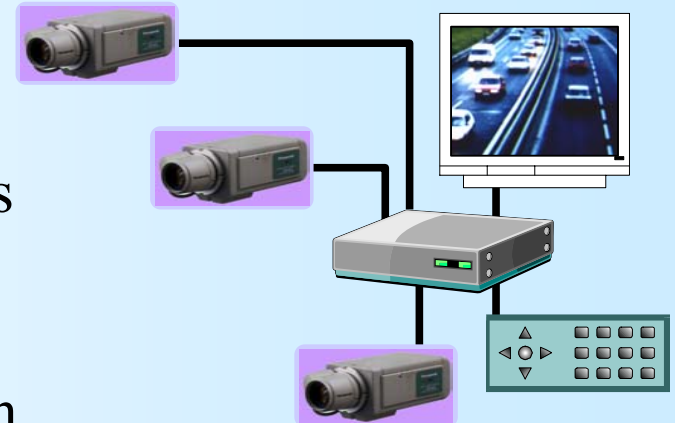

Tunnel Monitoring & Control System (TMCS)

Traffic Management & Control System (TMCS)

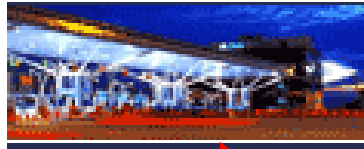

Toll Collection

Operations Interface

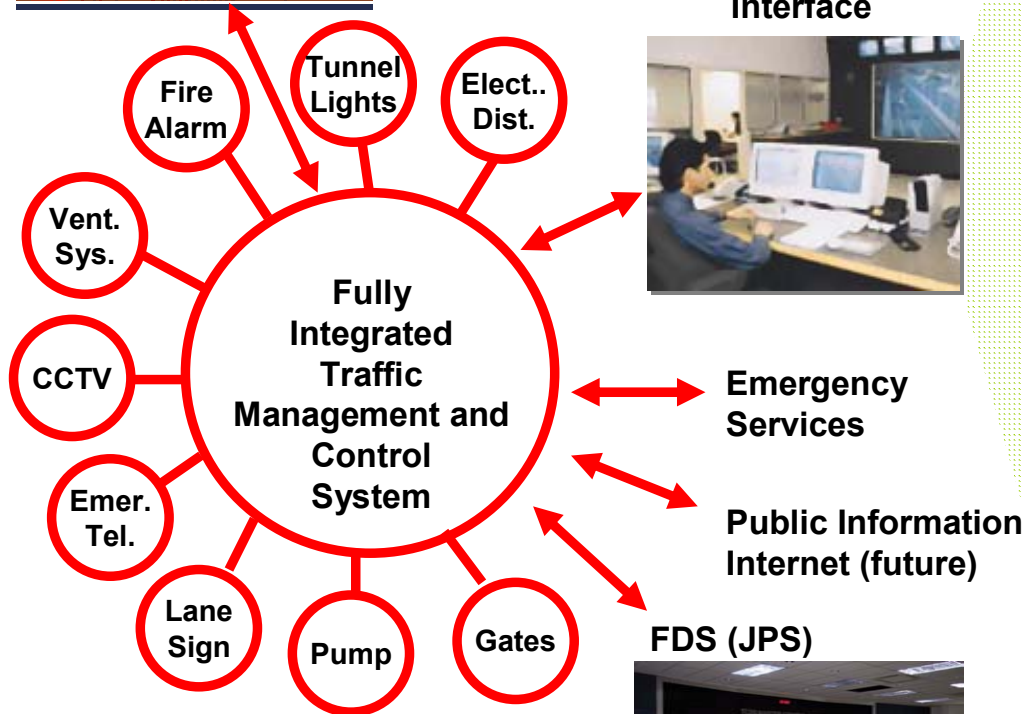

Electrical Distribution System Monitoring

Tunnel Lighting Control and Monitoring

Ventilation System Control and Monitoring

Fire Protection System Monitoring

Emergency Telephone System Monitoring

Emergency Response Plan

Automatic Incident Detection

Alarm logging



Event 1

Tunnel Closure from Mode 2 to Mode 3

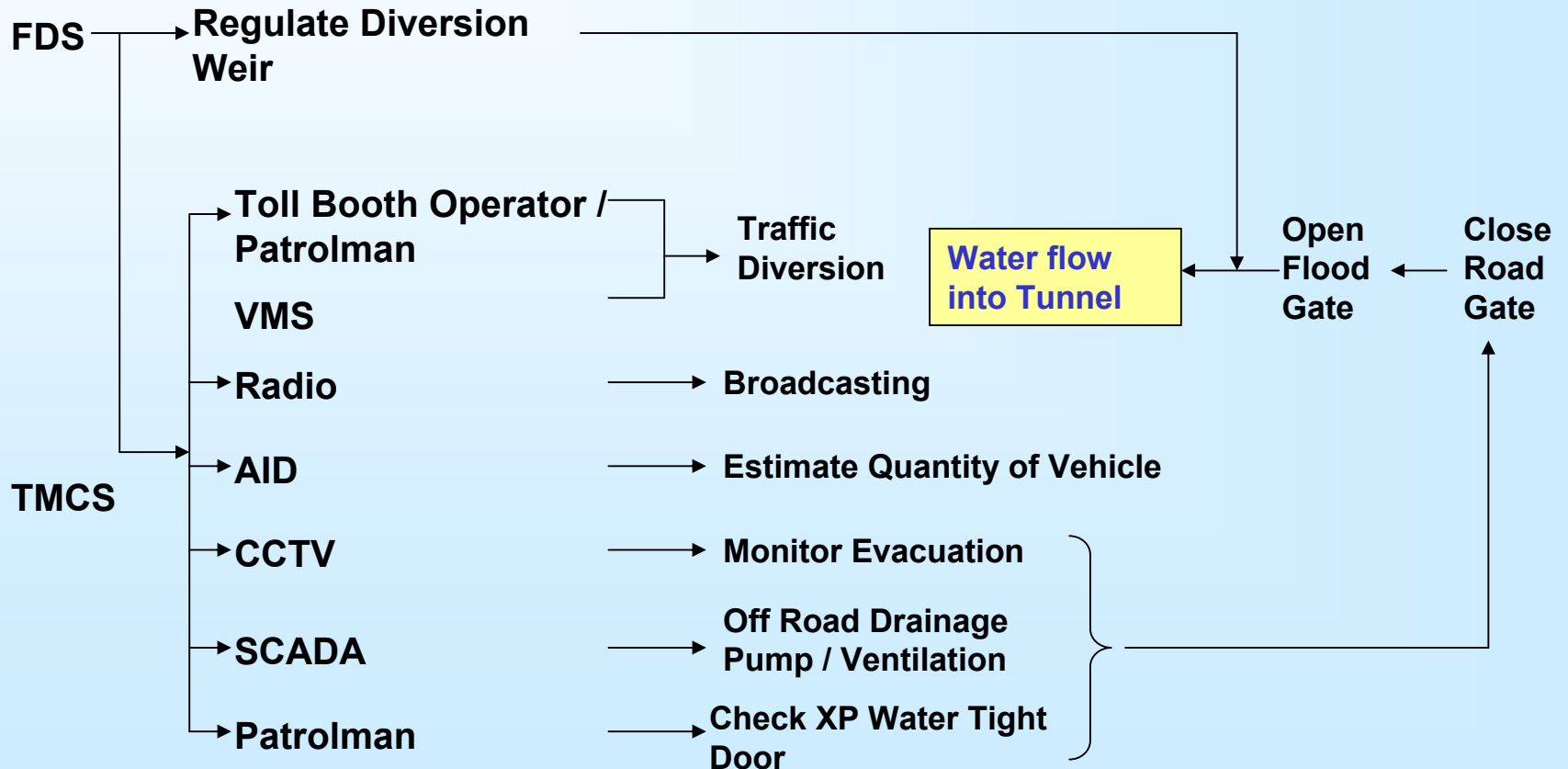

Event 2

Traffic Accident

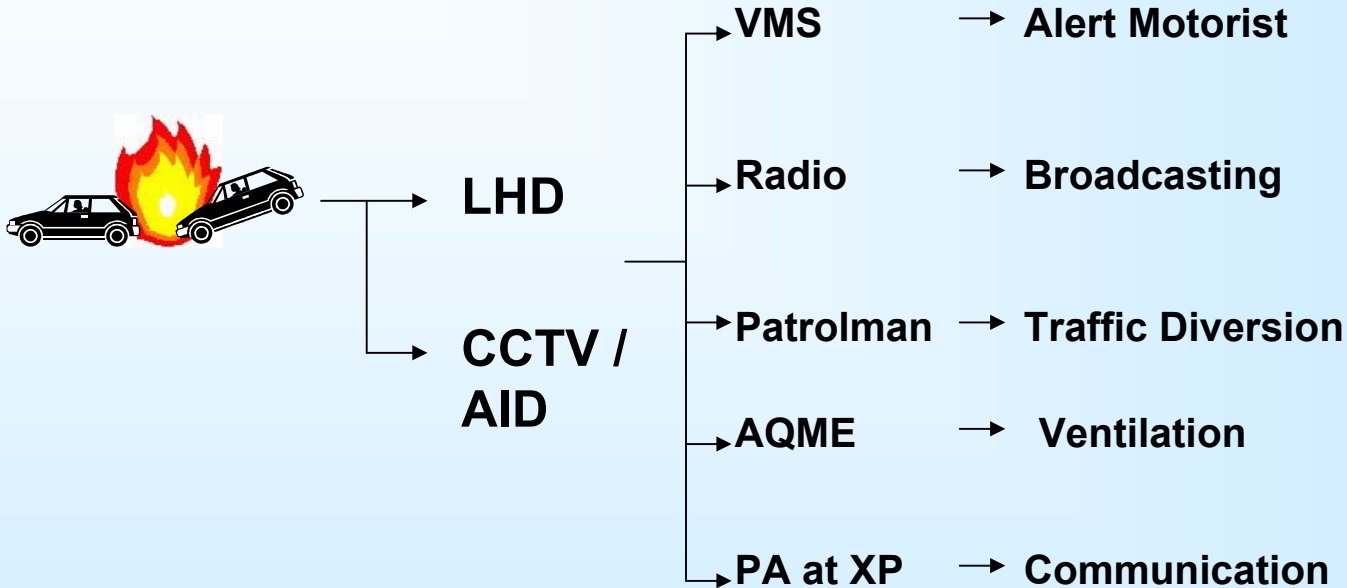

Event 3

Fire Accident

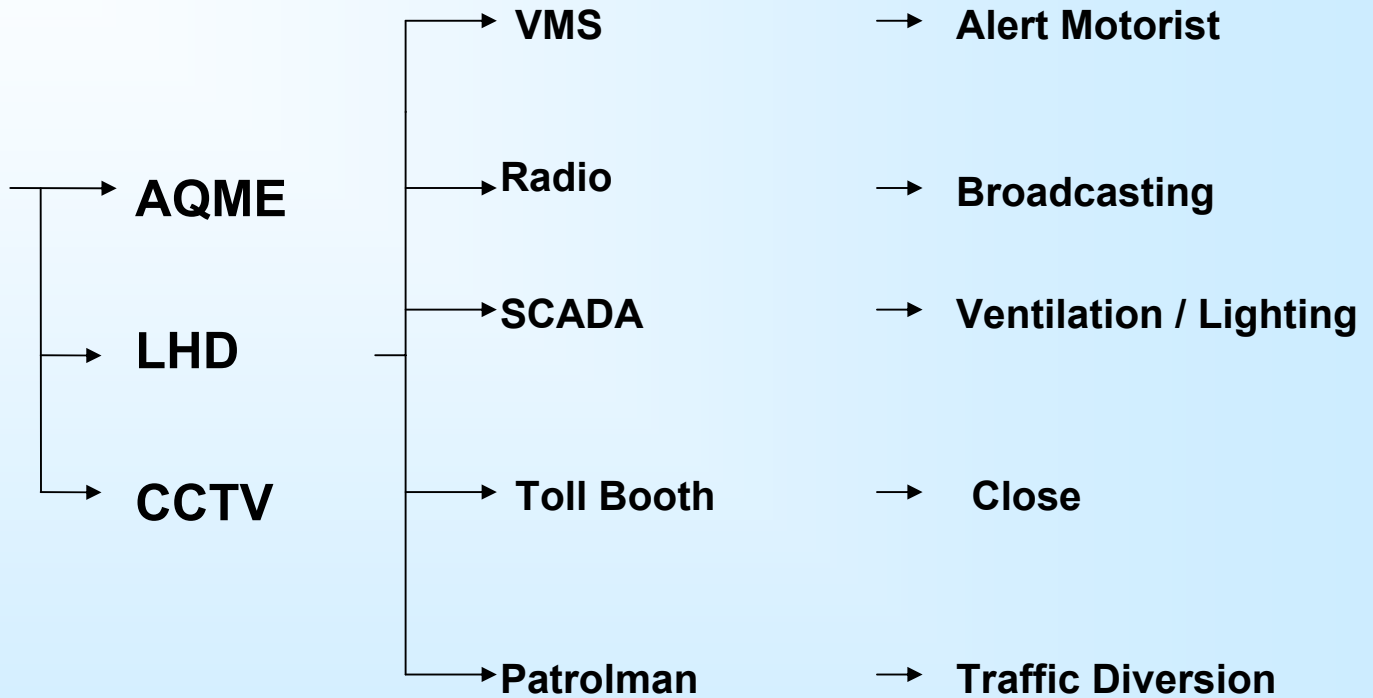

EVENT 3 : Fire Accident

Cross Passage and Emergency Escape

- Cross passages linking both tunnel road decks with stairs spaced approximately 250m intervals.
- Shaft Buildings at approximately 1km apart with stairs and lifts connecting the two road decks to the surface

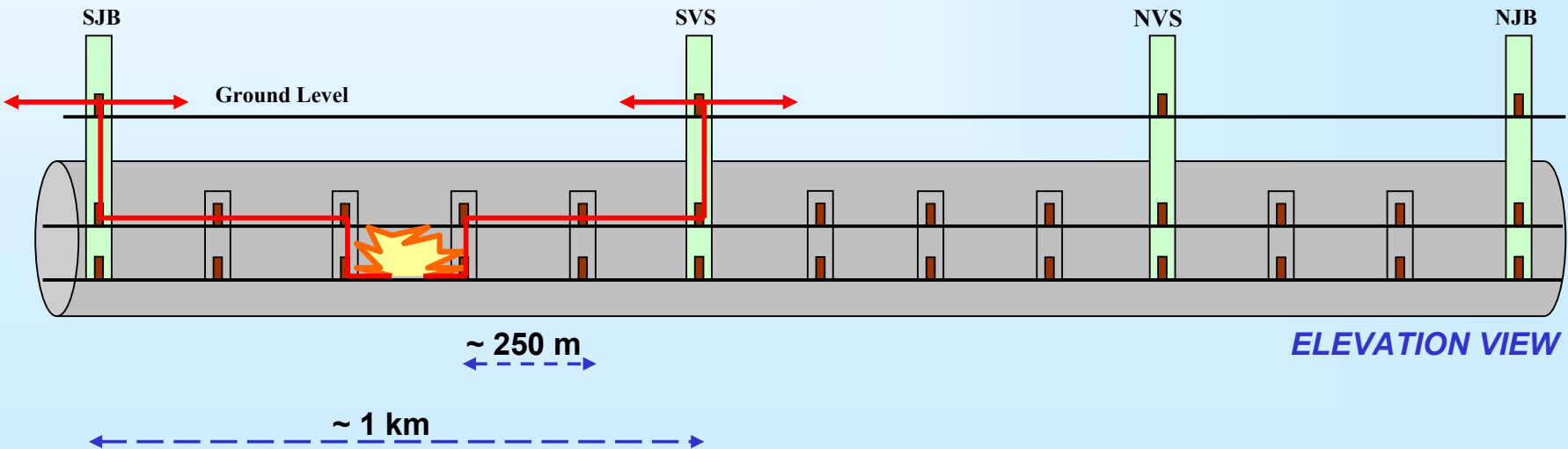

EVENT 3 : Fire Accident

Ventilation System

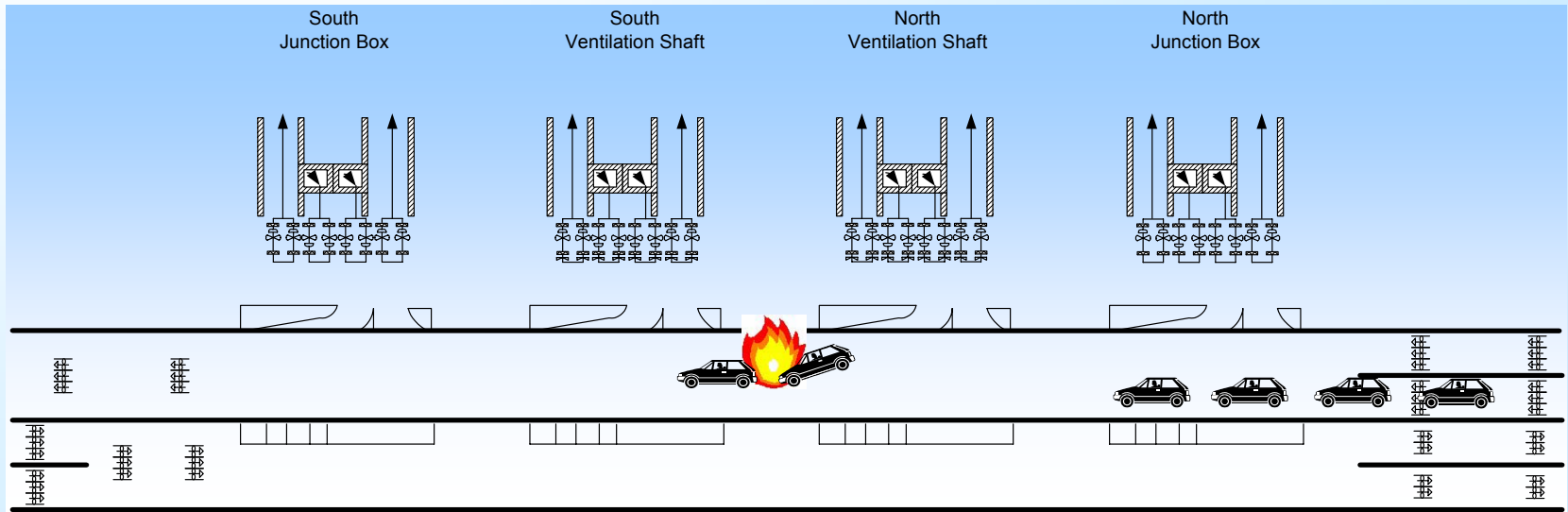

EVENT 3 : Fire Accident

Cross Passage and Emergency Escape

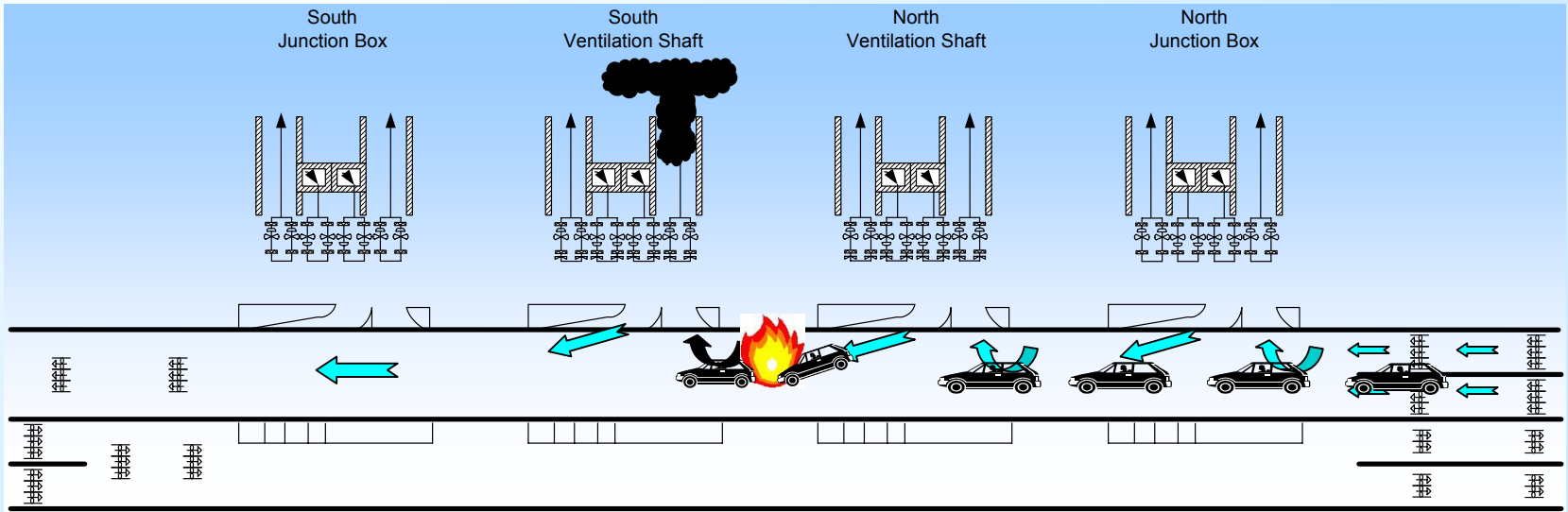

THANK YOU
Terima Kasih

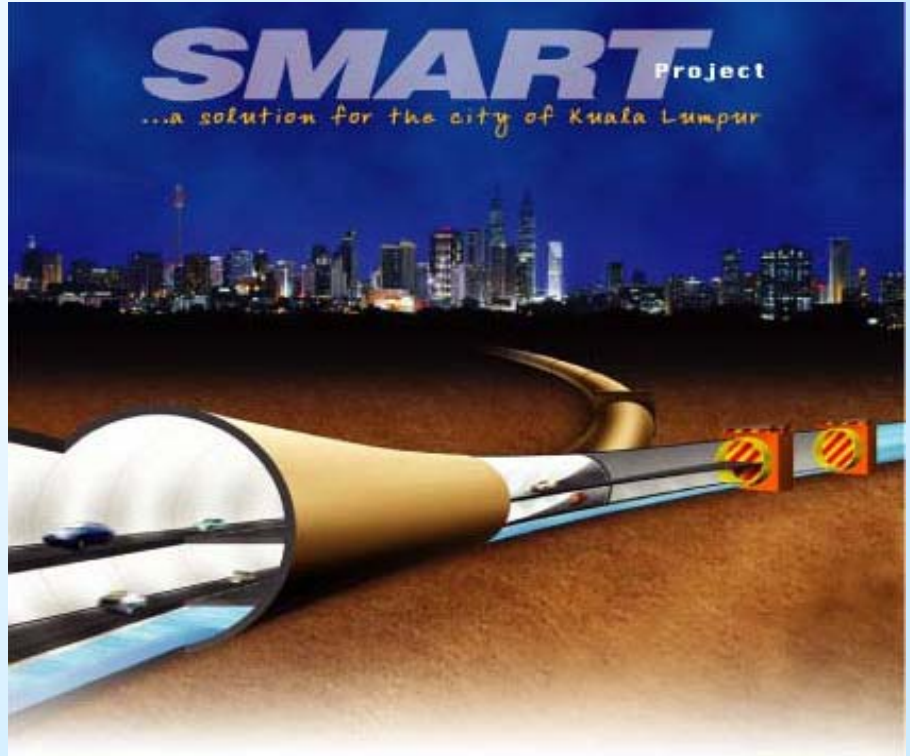

www.smarttunnel.com.my
